



8720 LAMBRIGHT ROAD
HOUSTON, TEXAS 77075
PHONE: (713) 987-0336, FAX: (713) 987-0355
www.acsi-us.com



PHANTOM 2000 PORTABLE HEPA FILTRATION UNIT
PART ORDER NUMBER: PH2000

OPERATING & MAINTENANCE MANUAL

DOCUMENT NUMBER: OPMM-005E-R0

RELEASES:

1. Original Release: January 27, 2005

NOTE:

1. The purpose of this document is to provide basic operation and maintenance information for the PHANTOM 2000 PORTABLE HEPA FILTRATION UNIT.
2. This manual is limited to items stated within. Any changes, additions or modifications will require a document amendment approved by ADVANCED CONTAINMENT SYSTEMS, Inc.

REFERENCE DOCUMENTS:

1. Drawing Num. PH2000-ES-R0: Electrical Schematic
2. Drawing Num. PH2000-LD-R0: Ladder Diagram

INDEX:

1. GENERAL INFORMATION
2. DIMENSIONS
3. OPERATION
4. FILTRATION
5. FILTER REPLACEMENT
6. ELECTRICAL SCHEMATIC
7. LADDER DIAGRAM
8. REPLACEMENT PARTS LIST

NOTE:
ALL UNITS MANUFACTURED BY ADVANCED CONTAINMENT SYSTEMS INC. (ACSI) MEET ALL STANDARDS REQUIREMENTS SET BY THE AMERICAN NATIONAL STANDARDS INSTITUTE (ANSI) Z2.9, AND ARE OSHA APPROVED. ELECTRICAL COMPONENTS ARE "UL" LISTED AND "CSA" CERTIFIED.

1. GENERAL INFORMATION:

- 1.1 The PHANTOM 2000 PORTABLE HEPA FILTRATION UNIT is designed for indoor use and to provide the most efficient air filtration with three stages of filtration. One stage with HEPA (High Efficiency Particulate Air) filtration, that can remove 99.97% of particles 0.3 micron or larger from the air stream.

2. DIMENSIONS:

- 2.1 Length: 37.75"
- 2.2 Width: 26.5"
- 2.3 Height: 31.25"
- 2.4 Weight: 160 lb
- 2.5 Housing: 20 ga Galv
- 2.6 Air Flow (High): 1975 cfm
- 2.7 Air Flow (Low): 1000 cfm
- 2.8 Motor: 1.75 HP, 2 Speed
- 2.9 Power Supply: 115 VAC, 60 Hz, 20 amp

3. OPERATION:

CAUTION
**DO NOT OPERATE THE PH2000 WITHOUT THE HEPA FILTER INSTALLED!
OPERATING WITHOUT THE HEPA FILTER INSTALLED OR USING NON-APPROVED
POWER CORDS MAY CAUSE DAMAGE TO THE ELECTRICAL SYSTEM OR
MECHANICAL COMPONENTS. FAILURE TO COMPLY WILL VOID ALL WARRANTIES.**

- 3.1 Electrical Requirements:
 - 3.1.1 The PH2000 requires a minimum of 115 VAC, 60 Hz, 20 amp, power supply for normal operation.
 - 3.1.2 The unit requires a heavy duty industrial grade 12-3 cord, in good condition, and should not exceed 50 ft. in continuous length for proper operation. If more than 50 ft is needed, please consult with your distributor.
 - 3.1.3 The unit needs to be grounded properly, including the ground pin on the plug. Keep electrical cords away from water and do not use a damaged cord.
- 3.2 Unit Set-up:
 - 3.2.1 The unit should be located away from doorways or other make-up air sources.
 - 3.2.2 Place the end of the exhaust port through an opening in the plastic barrier or wall covering, using duct tape to seal off any opening. Do not exhaust to uncontaminated or occupied areas.

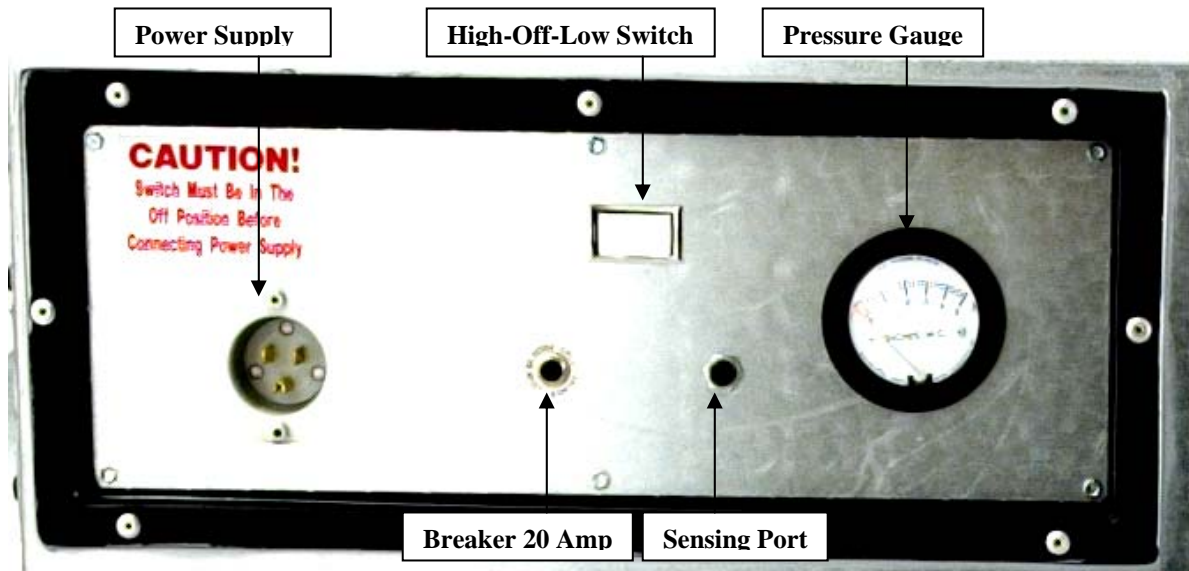

Fig. 1 Control Panel

3.3 Control Panel:

- 3.3.1 High-Off-Low Switch to start and select the speed of the unit
- 3.3.2 Push Button Breaker 20 Amp
- 3.3.3 Power Supply Receptacle
- 3.3.4 Pressure Gauge
- 3.3.5 Sensing Port

3.4 Turning unit **On**:

- 3.4.1 **The switch must be in off position, before connecting the power supply.**
- 3.4.2 The main switch is located on the control panel (see fig. 1) and is a three position switch (High-Off-Low). Push the switch to the right to operate in low speed or to the left to operate in high speed, the middle position is off.

3.5 Turning unit **Off**:

- 3.5.1 To turn the unit off, set the switch to the middle position.
- 3.5.2 At the end of the project, the filters should not be removed, instead the intake opening should be sealed with polyethylene film and duct tape.

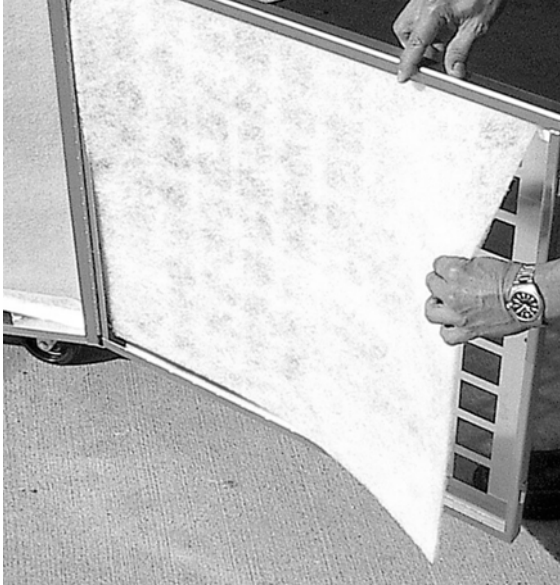

Fig. 2 Pre-filter Pad



Fig. 3 Ring Panel Filter

4. FILTRATION:

4.1 First Stage Filter (Pre-filter Pad):

4.1.1 24" x 24" x 1"

4.1.2 Double Ply

4.1.3 Removes large particles up to 10 microns and larger from the air flowing through the unit, thereby preventing premature loading of the second stage and HEPA filters. The pre-filter pad (see fig 2) is recommended to be changed as it becomes loaded and the airflow capacity of the unit decreases, or the pressure gauge at the control panel exceeds 2.6 inches at high speed or 1.9 inches at low speed, of W.C. (see fig 1).

4.2 Second Stage Filter (Ring Panel Filter):

4.2.1 24" x 24" x 1"

4.2.2 Triple Ply Ring Panel

4.2.3 Removes particles up to 1 micron and larger from the air flowing through the unit, thereby protecting the more expensive, HEPA filter. The ring panel filter (see fig 3) is recommended to be changed as it becomes loaded and the airflow capacity of the unit decreases, or the pressure gauge at the control panel exceeds 2.6 inches on high speed (1.9 inches on low speed) of W.C. (see fig 1).

4.3 Third Stage Filter (HEPA):

4.3.1 24" x 24" x 11.5"

4.3.2 99.97% Efficient

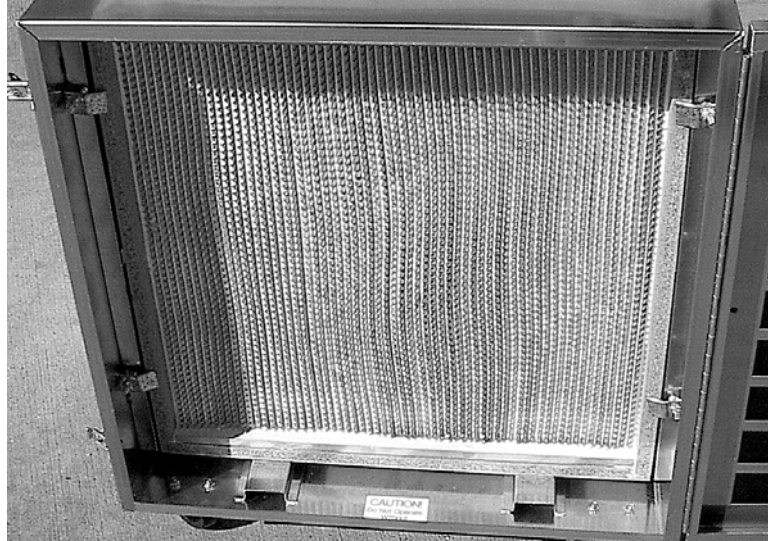

Fig. 4 HEPA Filter

4.3.3 Removes smaller contaminant particles up to 0.3 micron from the air flowing through the unit and has an efficiency rating of 99.97%. The HEPA filter (see fig 4) is recommended to be changed as it becomes loaded and the airflow capacity of the unit decreases, or the pressure gauge at the control panel exceeds 2.6 inches on high speed (1.9 inches on low speed) of W.C. (see fig 1). Or depending on the use, every 700 hours per agency recommendations.

4.4 Proper disposal of filters is described in Section 5.4 of this manual.

5. FILTER REPLACEMENTS:

ATTENTION
PERSONNEL RESPONSIBLE FOR CHANGING FILTERS, SERVICING OR RELOCATING THE UNIT, MUST WEAR APPROVED RESPIRATORS AND PROTECTIVE EQUIPMENT AND TO FOLLOW SAFE WORK PROCEDURE.

5.1 Pre-filter Pad Replacement:

- 5.1.1 Turn the PH2000 unit **off** and make sure to disconnect the power supply cord from the unit.
- 5.1.2 Open the door and remove the contaminated pre-filter pad.
- 5.1.3 Fold in the sides of the contaminated pad and dispose of as per section 5.4.
- 5.1.4 Install a new pre-filter pad.
- 5.1.5 Close the door and fasten draw latch.
- 5.1.6 Reconnect the power supply cord, then turn the unit **on**, and check the pressure gauge at the control panel.
- 5.1.7 If the pressure still exceeds 2.6 inches at high speed or 1.9 inches at low speed of water column on the unit's gauge, the ring panel filter also needs to be replaced.

Proprietary Information: This document is the property of ADVANCED CONTAINMENT SYSTEMS, Inc. It shall not be copied or duplicated and shall not be submitted to outside parties without the company consent.

5.2 Ring Panel Filter Replacement:

- 5.2.1 Turn the PH2000 unit **off** and make sure to disconnect the power supply cord from the unit.
- 5.2.2 Open the door and remove the contaminated ring panel filter.
- 5.2.3 Fold in the sides of the contaminated filter and dispose of as per section 5.4.
- 5.2.4 Install a new ring panel filter making sure to place it against the HEPA filter. This will position the filter properly.
- 5.2.5 Close door and fasten the draw latch.
- 5.2.6 Reconnect the power supply cord, then turn the unit **on**, and check the pressure gauge at the control panel.
- 5.2.7 If the pressure still exceeds the pressure stated above, the HEPA filter also needs to be replaced.

5.3 HEPA Filter Replacement:

ATTENTION

-THE NEW HEPA FILTER NEEDS TO BE THE SAME SIZE AND TYPE, AS THE ONE BEING REPLACED.

- WHEN THE HEPA FILTER IS REPLACED, THE PRE-FILTER PAD AND RING PANEL FILTER SHOULD ALSO BE REPLACED. THIS WILL HELP TO EXTEND THE LIFE OF THE HEPA FILTER

- 5.3.1 Turn the PH2000 **off** and make sure to disconnect the power supply cord from the unit.
- 5.3.2 Open the door and remove the ring panel filters, as described in section 5.2.
- 5.3.3 Remove the HEPA filter by loosening the four nuts and rotating the tabs to the open position.
- 5.3.4 Pull the HEPA filter out of the cabinet and dispose of as per section 5.4.
- 5.3.5 Inspect the gasket on the new HEPA filter housing before installation, to make sure there are no gaps, cracks, or defects. Any defects in the gasket will allow leakage of contaminated air through the unit.
- 5.3.6 Place the new HEPA filter in the unit with the gasket end facing the fan. Check to see that the filter lies squarely on the base bracket.
- 5.3.7 Push the HEPA filter against the HEPA flange bulkhead and rotate the locking tabs to the closed position.
- 5.3.8 Tighten the HEPA filter hold-down nuts securely to prevent air leaks.
- 5.3.9 Install ring panel filter as described in section 5.2.

5.3.10 Close door and fasten the draw latch.

5.3.11 Reconnect the power supply cord, then turn the unit **on**, and check the pressure gauge at the control panel. If pressure still exceeds the pressure stated above, consult your distributor.

5.4 Used filter disposal:

5.4.1 Used filters are considered contaminated waste and are to be disposed in compliance with all applicable regulations. Personnel replacing filters must wear personal protective equipment and follow safe work practices as per applicable regulations.

6. **ELECTRICAL SCHEMATIC:**

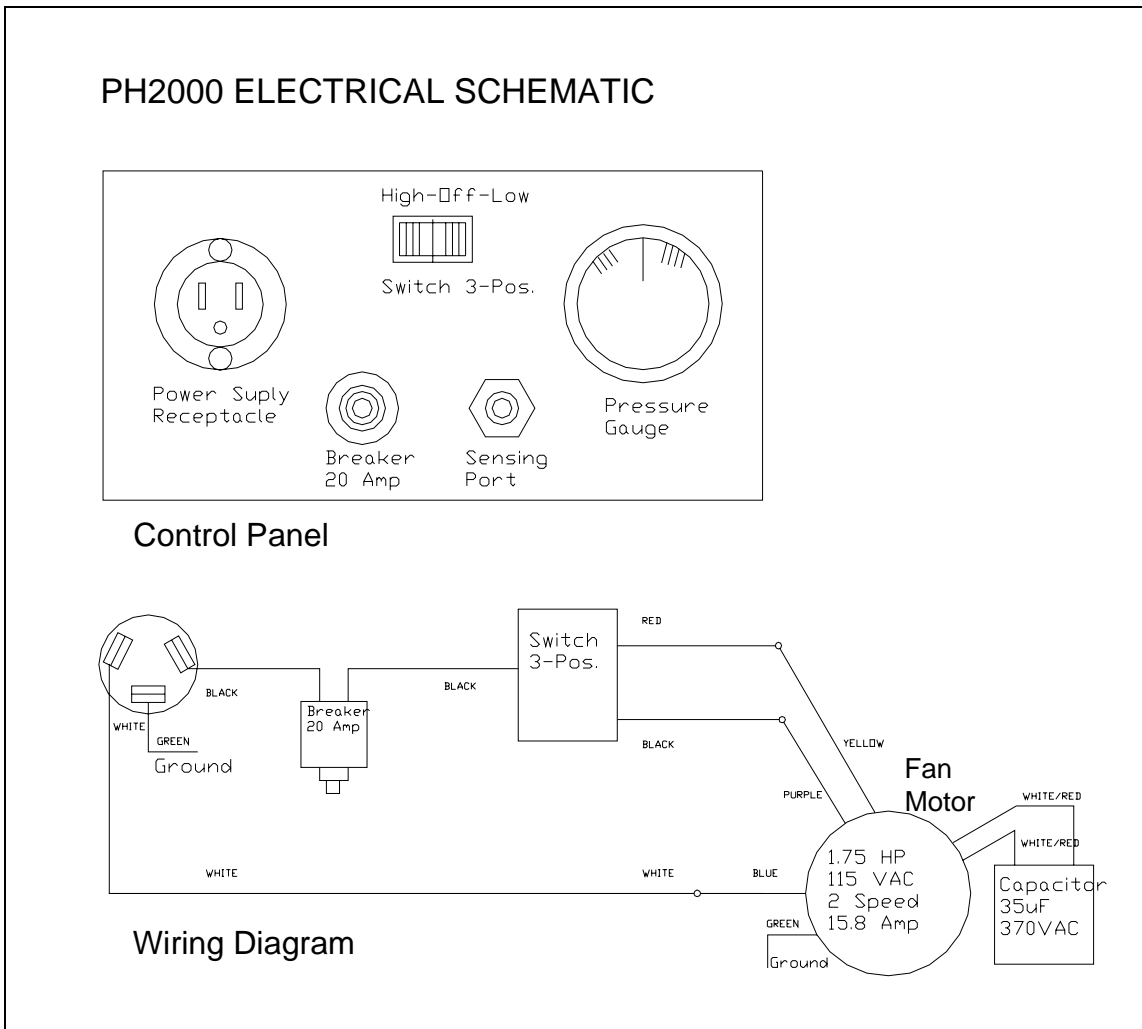

7. LADDER DIAGRAM:

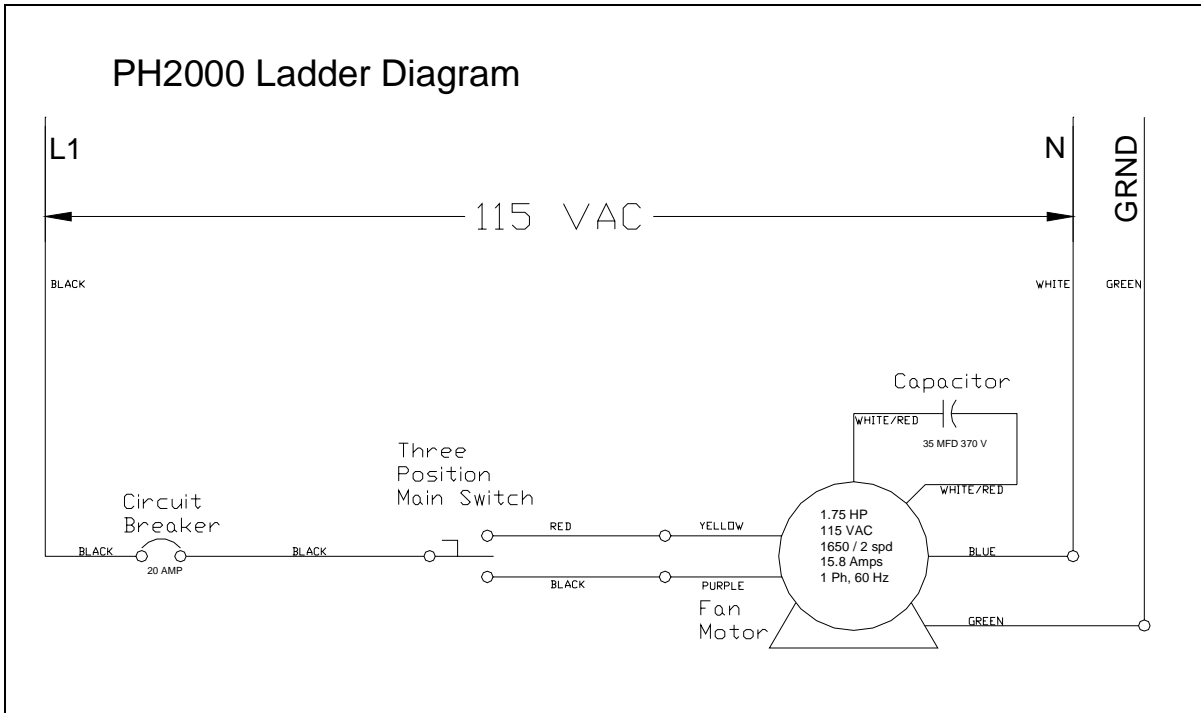

8. REPLACEMENT PARTS LIST:

Item:	Part Number:	Descriptions:
1	76012801	Blower Motor 1.75 HP
2	76252002	Blower for FA2000
3	38900424	FA2000 Motor & Blower Assembly
4	72650102	Capacitor 35uF, 370VAC, 50/60Hz
5	Call Dist.	HEPA Filter 24" x 24" x 11.5"
6	Call Dist.	Ring Panel Filter 24" x 24" x 1"
7	Call Dist.	Pre-filter Pad 24" x 24" x 1"
8	32000006	FA2000 HEPA Clips
9	32000012	FA2000 Control Panel
10	66020101	Gauge - Pressure Minihelic
11	72150202	Breaker - 20 Amp Push Button
12	72270301	Switch – SPDT 3 Prong
13	72250301	PS Receptacle – Recessed Male 15 Amp
14	74100101	Link lock (Draw Latch) – No Spring
15	74100201	Link lock - Keeper Plate
16	74500104	Caster 4" Swivel
17	74500204	Caster 4" with brake
18	74090101	Grab Handle with spring
19	71200204	Terminal, Push On 16-14 Female clear
20	83500101	FA2000 ABS Control Box

Proprietary Information: This document is the property of ADVANCED CONTAINMENT SYSTEMS, Inc. It shall not be copied or duplicated and shall not be submitted to outside parties without the company consent.