



**8720 LAMBRIGHT ROAD  
HOUSTON, TEXAS 77075  
PHONE: (713) 987-0336  
FAX: (713) 987-0355  
[www.acsi-us.com](http://www.acsi-us.com)**



**HEAT WAVE III PORTABLE WATER HEATER UNIT  
PART ORDER NUMBER: HWIII**

**OPERATING & MAINTENANCE MANUAL**

**DOCUMENT NUMBER: OPMM-006E-R0**

**RELEASES:**

1. Original Release: February 14, 2005

**NOTE:**

1. The purpose of this document is to provide the basic operation and maintenance information for the HEAT WAVE III PORTABLE WATER HEATER UNIT.
2. This manual is limited to items stated within. Any changes, additions or modifications will require an amendment approved by ADVANCED CONTAINMENT SYSTEMS, Inc.

**REFERENCE DOCUMENTS:**

1. ACSI Drawing Num. HeatWaveIII-ES-R0: Electrical Schematic
2. ACSI Drawing Num. HeatWaveIII-LD-R0: Ladder Diagram

**INDEX:**

1. GENERAL INFORMATION
2. DIMENSIONS / SPECIFICATIONS
3. OPERATION
4. PREVENTIVE MAINTENANCE
5. LADDER DIAGRAM
6. ELECTRICAL SCHEMATIC
7. REPLACEMENT PARTS LIST

**1. GENERAL INFORMATION:**

- 1.1 Heat Wave III is a versatile unitized high-volume blending diesel fired water heater. Heat Wave III was designed with simplicity of operation and serviceability in mind. Its rugged, compact square tubing steel frame construction and integrated water management system make it easy to use in close quarters. The heavy-duty wheels make it easy to load, unload, and transport. A high efficiency heavy-duty ¾" schedule 40 heat exchanger enables Heat Wave III to deliver high water flows with minimal pressure drop, at up to 50 degrees of temperature rise. A state of the art weatherproof, microprocessor controller with LED readout, precisely modulates outlet temperature for user comfort.
- 1.2 Heat Wave III has redundant flow and temperature safety valves, a ground fault circuit interrupter, a 5-gallon heavy-duty removable steel jerry can fuel tank and quick-coupled fuel supply lines for easy refueling.

**2. DIMENSIONS / SPECIFICATIONS:**

2.1	Length	35"
2.2	Width (Including wheels)	24"
2.3	Height	46"
2.4	Weight	205 lb
2.5	Min. Input Flow	12 gal/min
2.6	Input Pressure	40 - 120 psi
2.7	Max. Output Pressure (factory set)	40 psi
2.8	Max. Flow Rate	10 gal/min
2.9	Max. Fuel Consumption	1.77 gal/hr
2.10	Thermal Capacity/hour	248,000 BTUH
2.11	Temp. Rise at 14 gal/min	50° F
2.12	Max. Outlet Temperature (high limit)	92° F
2.13	Temperature Control	Electronic
2.14	Fresh water outlets	2 w/valves
2.15	Solution Outlets (optional)	2 w/valves
2.16	Fuel Tank Capacity	5 gallons
2.17	Power Requirements	115 VAC, 60 Hz, 5.5 Amp

### 3. OPERATION:

#### 3.1 Requirements:

**CAUTION**  
HEAT WAVE III REQUIRES A SUPPLY OF FRESH WATER WITH A PRESSURE OF 40 TO 120 PSI, AND A MINIMUM INPUT FLOW OF 12 GALLONS PER MINUTE. IT WILL NOT OPERATE IF WATER SUPPLY IS INSUFFICIENT OR SHUT-OFF.

- 3.1.1 Heat Wave III requires a power supply of 115 VAC, 60 Hz, 5.5 amp, minimum for normal operation.
- 3.1.2 Heat Wave III requires US#1 or #2 automotive diesel, US#1 or #2 home heating oil, Kerosene, or JP4.
- 3.1.3 Heat Wave III requires a heavy-duty industrial grade 12-3 cord in good condition and should not exceed 50ft in continuous length, to operate properly. If more than 50ft is needed, please consult with your distributor. Unit needs to be properly grounded, including the ground pin on the plug. Keep electrical cords away from water and do not use any damaged cord.
- 3.1.4 In addition, decontamination solution (if applicable).

#### 3.2 Unit Set-up:

- 3.2.1 Heat Wave III needs to be operated in areas where combustion is permitted (open flame areas). The unit produces combustion byproducts and requires the unit to be located in well-ventilated areas where there is no chance for accumulation of exhaust gases.
- 3.2.2 Heat Wave III should not be operated in enclosed and/or inhabited areas or up-wind of areas in which people will be present. **Heat Wave III requires fresh air for combustion.**

#### 3.3 Start-Up Procedure:

- 3.3.1 Make sure the switch on the control panel (Fig.1) is in the "off" position.



**Fig. 1 Control Panel**

- 3.3.2 Uncouple both fuel lines from the fuel tank cap and fill fuel tank with fuel.

**ATTENTION**

HEAT WAVE III NEEDS TO BE OPERATED WITH FRESH AND CLEAN FUEL. STALE AND/OR CONTAMINATED FUEL IS THE MOST COMMON SOURCE OF PROBLEMS WITH WATER HEATERS. HEAT WAVE III NEEDS TO BE OPERATED REGULARLY TO KEEP THE FUEL SUPPLY, FRESH AND CLEAN. IF IDLE FOR MORE THAN A MONTH, CONTACT YOUR DISTRIBUTOR FOR ASSISTANCE.

- 3.3.3 Re-couple the fuel lines and strap fuel tank back onto water heater.
- 3.3.4 Loosen fuel cap 1/8 turn to open breather port on fuel cap neck (Very important).
- 3.3.5 Connect power supply cable to suitable power supply and press reset button on GFCI unit.
- 3.3.6 Connect a 3/4" or larger supply hose to the inlet port on water heater.
- 3.3.7 Connect the delivery hose/s to the outlet ports on water heater.
- 3.3.8 Open the fresh water delivery valve/s and close solution valve/s.
- 3.3.9 Turn on water supply.
- 3.3.10 Allow water heater and connected equipment to flush out.
- 3.3.11 Make sure the heater is clear of all combustible materials and properly vented.
- 3.3.12 Set the switch on the control panel (Fig. 1) to the "on" position.
- 3.3.13 The temperature controller display will now show the incoming water temperature and the burner will fire.
- 3.3.14 As the burner cycles, the water temperature will increase. The display on the digital temperature controller will show the outgoing water temperature. When the heater reaches the set temperature, the burner will begin to short cycle to maintain the set temperature.
- 3.3.15 The temperature controller is programmed from factory at 92° F / 33° C for optimal temperature comfort.
- 3.3.16 If applicable, place the decontamination solution container in designated area close to Heat Wave III unit and submerge the solution dosing pump pickup line fully into solution. Now set the solution percentage to desired number by turning the handle adjacent to the pick up line on dosing pump.
- 3.3.17 Turn solution valve/s on for solution delivery. A tapping sound can be heard when the solution pump is activated.
- 3.3.18 To stop solution injection, simply turn the solution valve/s off.

3.4 Shut-Down Procedure:

- 3.4.1 Set the switch on the control panel (Fig. 1) to the "off" position.
- 3.4.2 Allow unit to cool down.

- 3.4.3 Turn water supply off.
- 3.4.4 Disconnect power supply cable.
- 3.4.5 Disconnect water supply hose and delivery hoses from all discharge ports.
- 3.4.6 Water heater will now gravity-drain completely.
- 3.4.7 In very cold conditions, additional protection is accomplished by “blowing” the unit down using a pressurized air source, to avoid freezing.

**4. PREVENTIVE MAINTENANCE:**

- 4.1 Although Heat Wave III is a low maintenance water heating system, some periodic care is still required for optimum operation. Outlined in the next few pages are those maintenance operations that the operator/maintenance personnel should perform periodically. Maintenance cycle periods naturally depend on amount of use.
- 4.2 Temperature and Pressure Relief Valve (Fig. 2):
  - 4.2.1 The temperature and pressure relief valve’s function is to protect the heater coil and by extension, the rest of the warm water supply system from elevated temperature and pressure. Periodically it is necessary to “exercise” it to make sure it is working correctly. This also flushes accumulated contaminants if any from the internal valve seat area.
  - 4.2.2 The Temperature and Pressure Relief Valve (Fig. 2) is located under the delivery valves and the manual activation handle is at the bottom of the valve.

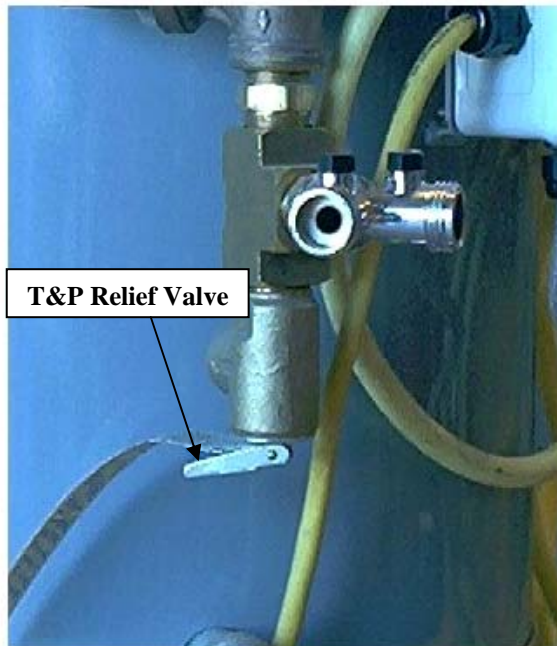

**Fig. 2 Temperature and Pressure Relief Valve**

- 4.2.3 To exercise the valve, set the switch on the control panel (Fig. 1) to the “off” position.

- 4.2.4 Close all the water heater delivery valves (Fig. 3).

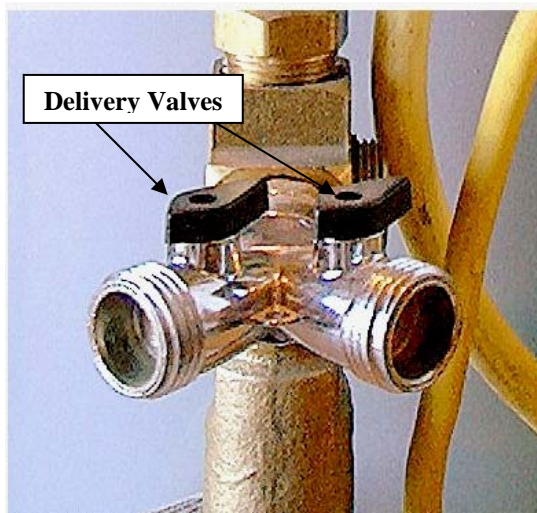

Fig. 3 Delivery Valves

- 4.2.5 Now pull down the manual activation handle on the T&P relief valve (Fig. 2) for about 5 to 10 seconds. Water will now flow out of the discharge line and flush the internal valve seat.
- 4.2.6 Lower the manual activation handle on the T&P valve (Fig. 2), open the water heater delivery valves (Fig. 3), and set the switch on the control panel (Fig. 1) to the "on" position.

- 4.3 Fuel filter (Fig. 6):

**ATTENTION**

HEAT WAVE III NEEDS TO BE OPERATED WITH FRESH AND CLEAN FUEL. STALE AND/OR CONTAMINATED FUEL IS THE MOST COMMON SOURCE OF PROBLEMS WITH WATER HEATERS. HEAT WAVE III NEEDS TO BE OPERATED REGULARLY TO KEEP THE FUEL SUPPLY, FRESH AND CLEAN. IF IDLE FOR MORE THAN A MONTH, CONTACT YOUR DISTRIBUTOR FOR ASSISTANCE.

- 4.3.1 Fuel filter care is an essential part of Heat Wave III's preventative maintenance procedure, and it needs to be cleaned periodically to prevent major contamination.
- 4.3.2 To start the procedure, place a container under the filter to catch the fuel that will be spilled during disassembly. Now with a 5/8" wrench (Fig. 4) loose the bolt on the top of the filter head while firmly holding the filter bowl.
- 4.3.3 At times, a dry seal between the bowl and the filter head can make the bowl hard to separate. A gentle tap on the upper part of the bowl while firmly supporting the filter will help separate the parts.



**Fig. 4 Fuel Filter**

- 4.3.4 Remove the center bolt (Fig. 5) making sure, the red washer (see arrow in Fig. 5) is not lost. This sealing washer prevents fuel leaks when the burner is off and air leaks into the fuel system when the burner is on.



**Fig. 5 Fuel Filter – Center Bolt**

- 4.3.5 Separate the bowl (Fig. 6) from the head to expose the fiber element and pour the fuel in bowl into the container.
- 4.3.6 The filter is composed of several bands of wool and a center screen. It is not necessary to disassemble the components of the element to clean it, just rinse properly. Although the element is reusable (if properly cleansed with mineral spirits and blown clear), we recommend one or two elements be stocked at all the time for quick turn around. Please contact your local distributor for replacement parts.



**Fig. 6 Fuel Filter – Fiber Element**

4.3.7 A breakdown of the fuel filter is shown in Fig. 7.

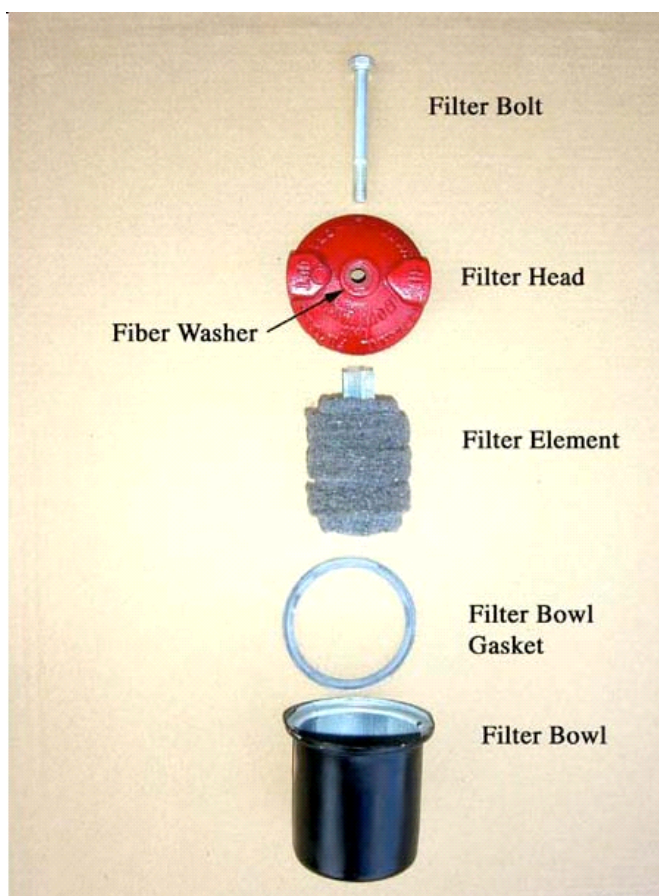

**Fig. 7 Fuel Filter - Breakdown**

4.4 To Reassemble:

4.4.1 To reassembly the filter, simply follow the reverse order. Make sure to insert the filter element carefully to avoid damage the screen. Verify all seals are properly seated before placing the heater back in service to assure there are no fuel or air leaks.

4.5 **Note:** In cases of heavy fuel filter contamination, the entire fuel system should be checked. Severe contamination can affect the fuel pump and/or the fuel nozzle assembly. This level of service is for a trained oil fired burner technicians, please contact your distributor for an approved service provider in your area.

5. **LADDER DIAGRAM:**

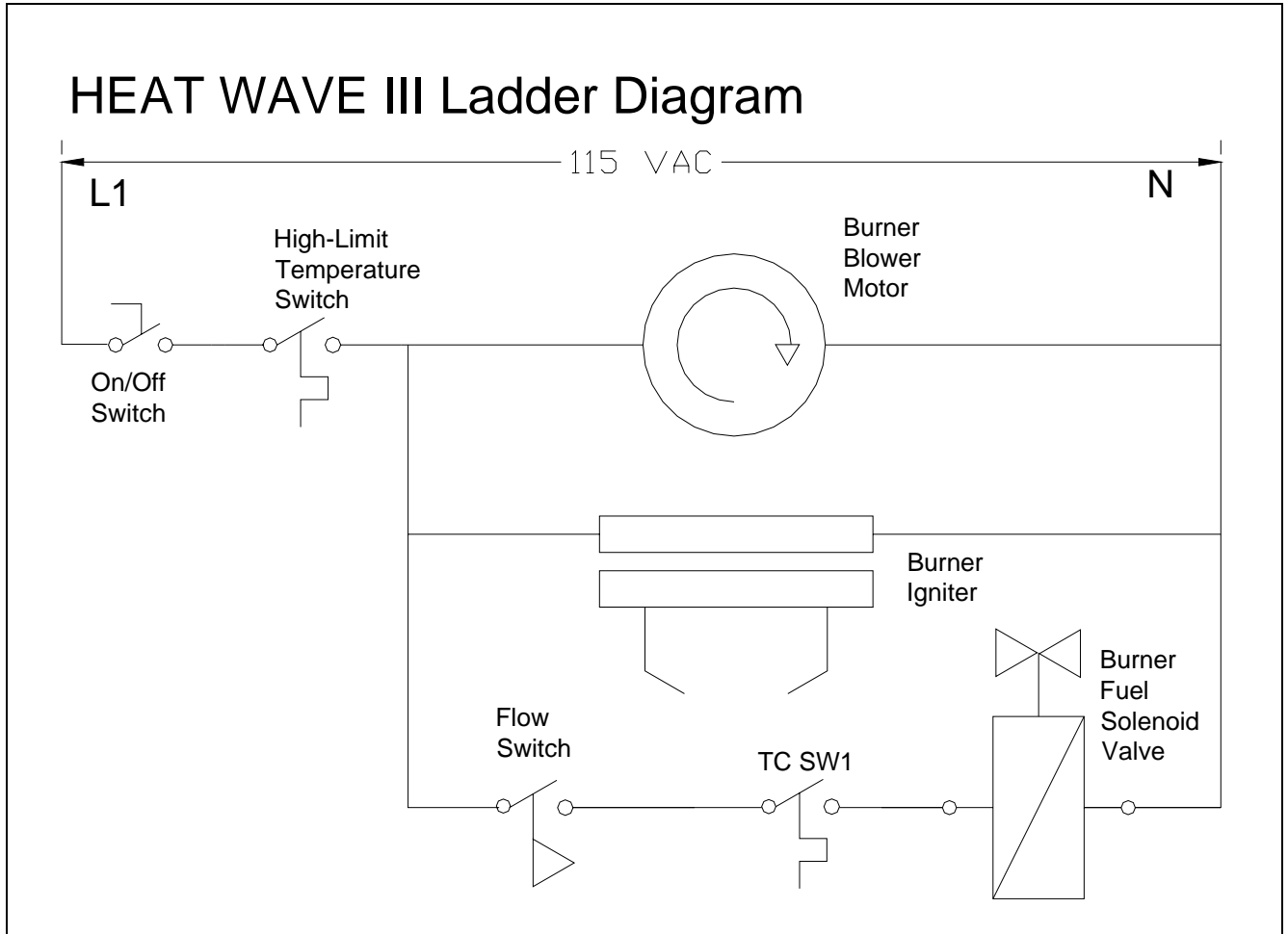

6. **ELECTRICAL SCHEMATIC:**

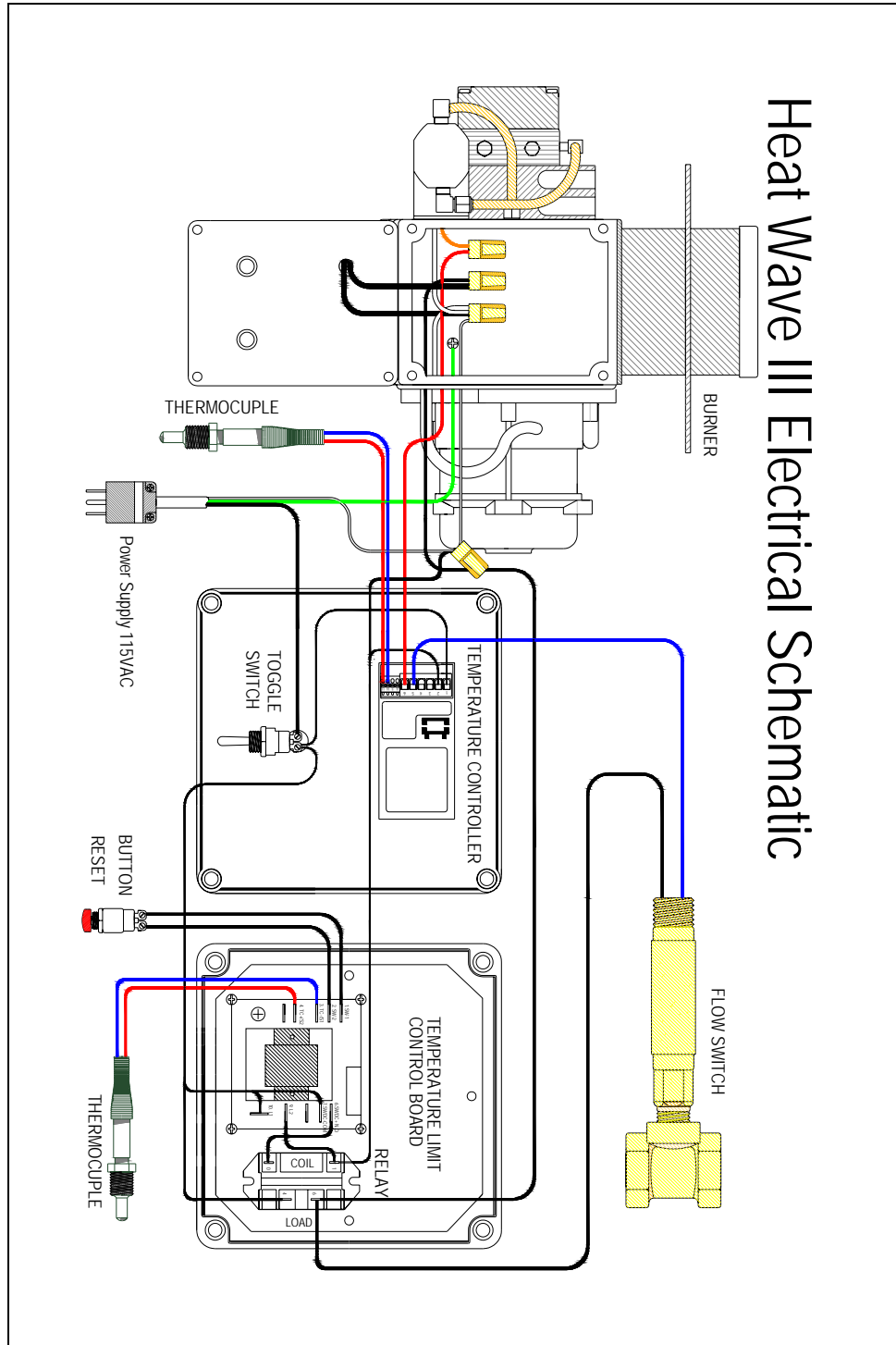

**7. REPLACEMENT PARTS LIST:**

<b>Heat Wave III Replacement Part List:</b>		
<b>Item:</b>	<b>Part Number:</b>	<b>Descriptions:</b>
1	56220105	Fuel Tank GI Jerry Can 5 Gal
2	56220106	Fuel Tank Holder
3	61010103	Fuel Tubing 1/4"
4	61080003	Hose Clamp #4
5	61080012	Hose Clamp #12
6	61090402	Hose Barb for Fuel Tank
7	61090404	Hose Barb for Fuel Pump
8	71240805	Cord Grip
9	72270401	Switch-Toggle On/Off
10	72271100	Flow Switch
11	83180101	Toggle Switch Boot
12	87060410	Pressure Regulator Valve
13	97000177	Garden Hose Swivel
14	97000180	Cable 18/4
15	97000209	Quick Disconnect Socket
16	97000210	Quick Disconnect Plug
17	97000219	Burner
19	97000278	Valve Y-Connector
20	97000284	Fuel Filter 1/4" FPT In/Out
21	97000384	GFCI Outlet
23	97000478	Thermo Coupler
24	97000479	High Limit Switch
25	97000480	Power Relay 30 Amp
25	97000486	Wheel 14" TUFF
26	97000509	Boiler Coil W/O Skin
27	97001075	Switch Push Button
27	97001083	Temperature Controller
28	Call Srvc Cntr	Flue Cap
29	Call Srvc Cntr	Heater Coil
30	Call Srvc Cntr	Burner Gasket
31	Call Srvc Cntr	Burner Fuel Nozzle
32	Call Srvc Cntr	Burner Electrodes
33	Call Srvc Cntr	Burner Blower Motor
34	Call Srvc Cntr	Burner Ignitor
35	Call Srvc Cntr	Burner Blower Wheel